**KIT PART NUMBER 6730030
INSTRUCTIONS FOR INSTALLING A
NEW CUP STATION SUPPORT GUSSET
ON 673, 675, & 677 MACHINES**

CHECK THE PARTS RECEIVED IN THE KIT WITH THE PARTS LIST IN THESE INSTRUCTIONS. IF ANY PARTS ARE MISSING, CONTACT THE NATIONAL VENDORS PARTS DEPARTMENT IMMEDIATELY.

Read these instructions carefully before installing the kit.
Keep these instructions for part numbers and for future reference.

This kit contains the following :

PART NUMBER	DESCRIPTION	QUANTITY
1451097	SCREW - #8-32X.31 HEX HD.TF - BLACK	2
6730029	KIT INSTRUCTIONS - NEW CUP STATION SUPPORT GUSSET	1
6738013	GUSSET - CUP STATION SUPPORT	1

TOOLS REQUIRED:

- a. One power drill.
- b. One drill bit .141 to .136 Dia. (No. 28, 29 or 9/64")
- c. One ¼ inch nut driver.

WARNING: Electrical Shock Hazard - Turn machine off before installing this kit. Failure to do so could result in electrical shock.

1. Read these instructions carefully before installing this kit.
2. Turn the machine OFF with the main switch. Failure to do so could result in an electrical shock.

-
3. Remove the top right side screw that attaches the Cup Station Support and attach the new Gusset (6732013) as shown in Figure 1.

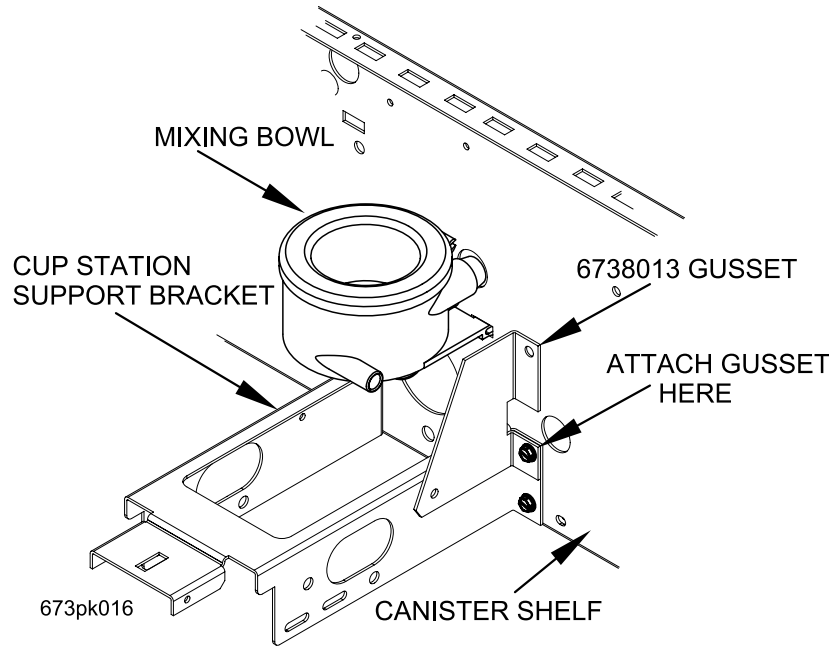

Figure 1

4. Drill one .141/.136 Dia. hole into the Cup Station Support using the Gusset as a template as shown in Figure 2. Insert one of the 1451097 screws in this hole.

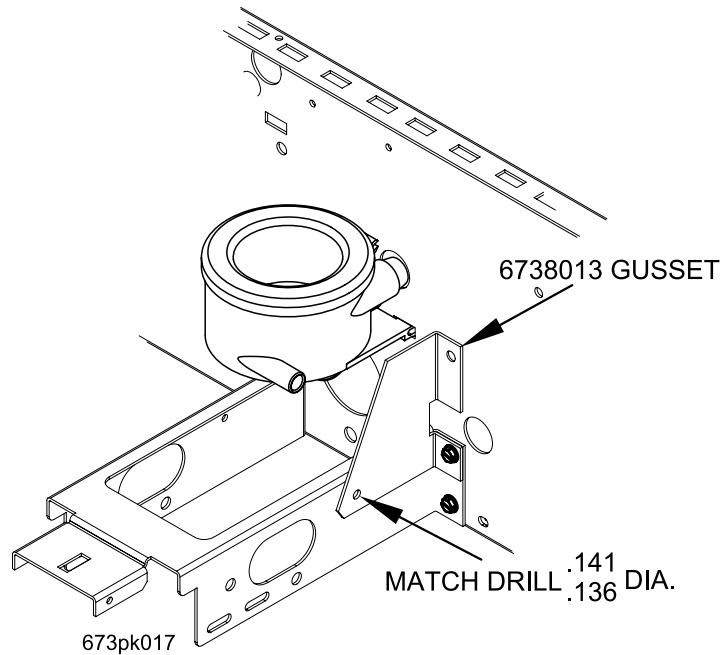

Figure 2

-
5. Drill one .141/.136 Dia. hole into the Canister Shelf using the Gusset as a template as shown in Figure 3. Insert one of the 1451097 screws in this hole.

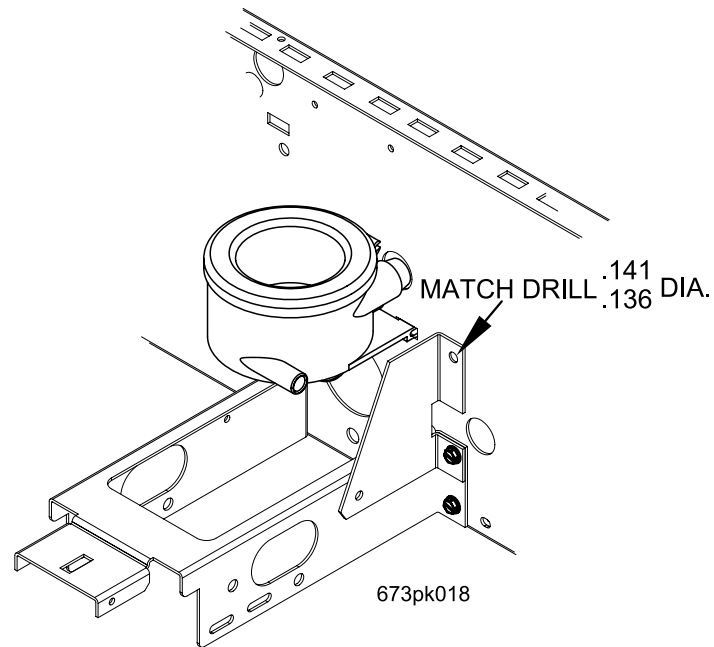

Figure 3

6. Reattach any hoses or tubing removed previously.
7. Turn the machine on with the main switch.